

Reinforced Concrete Dapped End Beams – State of the Art

Qasim M. Shakir¹

¹ Civil Engineering, Faculty of Engineering, University of Kufa, Iraq

Correspondence: Qasim M. Shakir, Civil Engineering, Faculty of Engineering, City ZIP/Post code: 54001, Iraq.
Tel: 964-7832-460-562.

Received: October 1, 2018; Accepted: November 12, 2018; Published: November 21, 2018

Abstract

This paper represents a historical review, on the experimental studies carried out to investigate the behavior of non-prestressed dapped end beams. The specimens discussed are made of normal, high-strength and self-compacting concrete and subjected to several systems of loading setup. Different values of the (shear span-to-effective depth) ratio that were adopted by researchers are discussed. Some specimens are full scale other are prototypes. Different methods and suggestions by previous studies to strengthen the dapped end. Different failure modes that have been recognized based on detailing, dimension and material properties of the dapped end beams. Several parameters that may affect the behavior of dapped end beams are reported. Many shown also, the conclusions that have been drawn from various studies. In addition, some suggestion for future work are proposed and to extend studies about the behavior of the dapped end beams. Finally, a comprehensive list of references is provided.

Keywords: dapped end beams, diagonal strut, shear failure, depth-to-span ratio

1. Introduction

Since the last years of the 20th century, precast concrete (PC) industry have become more popular around most of the world. PC structure has several merits in comparison with a cast-in-place one as the quick construction, more strength and durability (resistant to rot, mold, etc.), ability to eliminate beams and columns on the building perimeter, energy efficiency and excellent appearance, good noise reduction. In general, PC structures are segmented and can be connected using different types of linking elements. One connection details that are widely used in precast buildings and multi-story garages is the dapped end. A dapped end is achieved when the web of a beam is notched at the bottom corner, moving the bearing location higher in the cross-section providing better lateral stability of the beams and girders (Lu et al., 2015). The notch itself is known as the “dap” and the part of concrete being above the dap is called as the nib. The dapped end detail enables the overall depth of a precast slab or roof structure to be reduced by recessing the supporting corbel or L-edge into the supported beam. Thus, reducing significantly the overall height of a building providing an efficient and economical construction system.

Because that the flow of internal stresses is interrupted by the sudden change in geometry; zones of non-uniform stress distribution (disturbance in flow) are caused close to the re-entrant corner and in the nib. Heavy stress intensity at the re-entrant corner due to the high bearing reaction and the sudden changes in geometry. Such regions of discontinuity in a member are referred as disturbed regions (D-regions). A bearing point is eccentric to the dap face and it may be accompanied by additional axial loads due to creep and thermal effects. Such loads must be safely resisted by transferring forces into the main cross-section of the beam through the reduced cross-section of the nib. Due to the complexity of the flow of stresses, traditional design methods are not adequate for designing dapped end beams; there are two main approaches to design the dapped ends (and corbels) which are the shear-friction (PCI) method or the strut and tie (STM) modelling. Both approaches requires the investigation of the potential failure modes. In addition, the designers frequently ignore some significant aspects such as proper details and the need for checking the stresses in the concrete. These omissions often yield poor serviceability, e.g. no prohibited cracking in the D-region, spalling of concrete cover, and may sometimes even cause premature brittle failure. Regarding the loading set-up, Figure 1, shows the main arrangement that observed through the different investigations; three with two dapped ends, while the forth is with one dapped end. Five modes of failure had been reported by the previous studies as shown in Figure 2.

In the present work, a review of the previous studies achieved to investigate the behavior of non-prestressed dapped end beams (DEB) is presented. Moreover, conclusions and directions for future work are proposed.

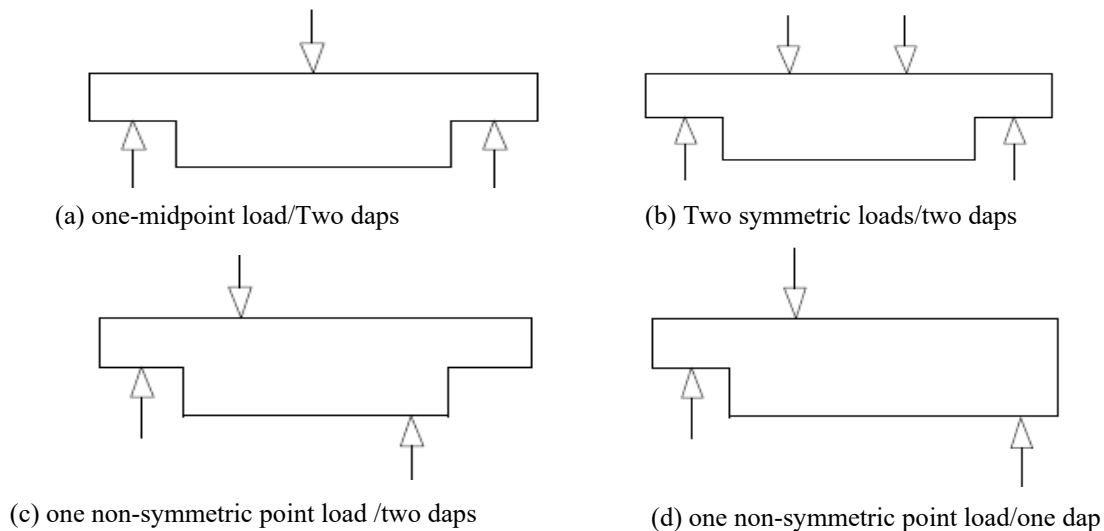

Figure 1. Different loading arrangements for Dapped end beams

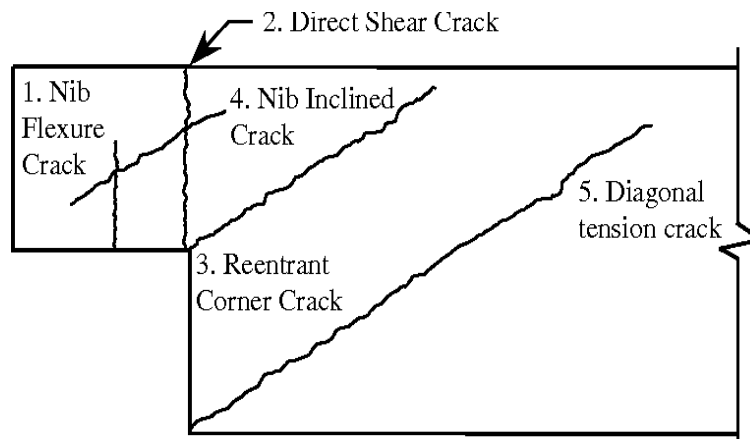

Figure 2. Failure modes for Dapped end beams (PCI Handbook, 2004)

2. Studies Concerning the Behavior of Reinforced Concrete Dapped End Beams

Several researchers have investigated the general performance of non-prestressed reinforced concrete dapped end beams. Mattock and Chan (1979), achieved one of the earliest studies in this domain. In this work, the dapped end was suggested to be designed as an inverted corbel following the design proposal of Mattock (1976). The difference was only that a hanger reinforcement is needed to develop a tension force to withstand the inclined compressive force of concrete in the dap, Figure 3a, instead of the compression force in the column in the case of a corbel, Figure 3b. Such force must not be less than the unfactored shear force. To check the validation of their proposal, eight dapped ends have been considered; four with vertical reactions only. Whereas the others were tested under a horizontal force in addition to the vertical reaction. The main parameters studied where the expression of shear span "a" (which equals to the distance from the vertical reaction to the center of the hanger reinforcement) and the amount of hanger reinforcement. They addressed that the first crack occurred at the reentrant corner at about 20% of failure load. Then, cracking developed at approximately 45 deg. to the horizontal. In addition, it was found that in most tests, the longitudinal reinforcement of nib yielded at the range of (70-95) percentage of the maximum load. At final stages of loading, compression spalling and the top face of the beam become inflated close to the point of load application.

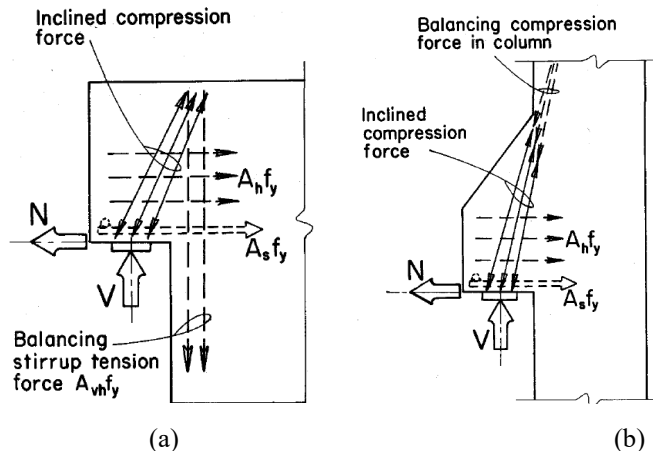

Figure 3. Internal force systems in (a) a dapped end (b) a corbel (Mattock and Chan, 1979)

Based on the test results, they proposed what so-called "shear friction" design procedure for dapped ends which is based on a simple system of equilibrium model (flexural model). This design approach was adopted by the PCI institute then by the ACI 318 code provided that $a/d < 1.0$. The main steps such approach are:

1. The ultimate shear stress in nib due to factored load (v_u) must not be greater than the limits in equation (1).

$$v_u = V_u / (\phi b d) \leq 0.2 * f_c \tag{1}$$

2. The amount of steel hanger reinforcement, $A_v h$, intersecting with the shear plane, to carry the total shear V_u need to be calculated according to equation (2):

$$A_v h = V_u / \phi f_y \tag{2}$$

3. The ultimate moment at reentrant corner need to be calculated, by equation (3):

$$M_u = V_u a + N_u (h - d) \tag{3}$$

4. The amount of reinforcement area, A_h , required to support the horizontal force, N_u , can be determined from equation (4).

$$A_h = N_u / \phi f_y \tag{4}$$

5. Calculate reinforcement area $A_v f$ to transfer shear across interface between extended end and the full-depth beam. Use "Shear Friction" provisions of ACI 318-77; Shear Friction of the PCI Design Handbook or the proposed "Modified Shear Friction" 3 equation:

$$A_v f = \{V_u / (\phi * 0.8) - K b d\} / f_y \geq 0.2 b d f_y \tag{5}$$

$K = 0.5, 0.25$ and 0.31 for normal weight; all-lightweight and sand lightweight concrete respectively

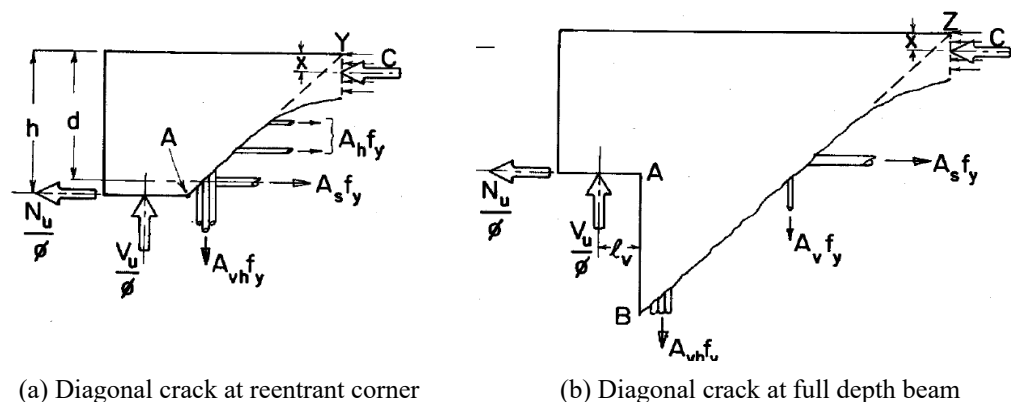

Figure 4. Design method proposed by (Mattock and Chan 1979)

6. The steel area of main (tension) reinforcement of the extended end, A_s , have to be the greater one of the following:

$$A_s = \begin{cases} A_f + A_n \\ \frac{2}{3}A_{vf} + A_n \end{cases} \quad (6)$$

7. Horizontal stirrups have to be provided in the lower two-thirds of the depth of the nib, having total area:

$$A_h = 0.5(A_s - A_n) \quad (7)$$

8. Provide a suitable anchorage for nib end. Such bars must satisfy an embedment length into the beam of $(H - d + ld)$ beyond the critical section (section of change in depth) to develop their yield strength.

In 1983, Liem suggested a new method to enhance the strength of the hanger region through the use inclined hanger reinforcement to interrupt the diagonal cracks emanating from the reentrant corner. Eight full-scale specimens with $(a/d < 1)$ were tested under the loading setup shown in Figure 1c. He adopted the same dimensions and detailing as those of Mattock and Chan (1979), except inclined bars substituted the horizontal bars. Different amounts of hanger reinforcement and several shapes of dapped ends were considered. Then he explored the validity of Mattock procedure to estimate the capacity of dapped end beam with inclined hanger reinforcement.

He concluded that the maximum allowable nominal shear value could be increased to $0.3f_c$ of corbels and dapped ends with horizontal reinforcement and to $0.6f_c$ for the case of 45° inclined reinforcement. Regarding the economical view, he concluded that inclined reinforcement are $(\sqrt{2})$ times more than the horizontal reinforcement in terms of the amount of steel required and that the shape of dapped end has no effect on the ultimate shear strength.

He proposed a new approach for the design of dapped ends with $a_s/h_D < 1$; as follows:

1- Calculate the ultimate shear force (V_u) and maximum moment (M_u) of the beam.

2- Calculate req. steel area A_{wf} or A_{hf} to resist full shear load;

$$A_{wf} = V_u / \Phi 1.41 f_y \quad \text{for inclined steel} \quad (8)$$

$$A_{hf} = V_u / \Phi f_y \quad \text{for horizontal steel} \quad (9)$$

3- Check ultimate shear strength of concrete

4- Check capacity of dapped end

$$V_u = 0.7 \Phi f'_c * b * h_D \quad (10)$$

Flexural tension strength of steel

$$T_{wf} = A_{wf} * f_y \quad (11)$$

$$\text{Horizontal component; } T_{HI} = T_{wf} * \cos 45 \quad (12)$$

$$T = T_{HI} + T_H \quad (13)$$

TH: additional tension strength of horizontal confinement reinforcement

$$a = T / (0.85 * f'_c * b) \quad (14)$$

Capacity of the dapped end

$$M = T(d_D - a/2) \quad (15)$$

Moment M at A should be greater than external moment, otherwise steps from 2

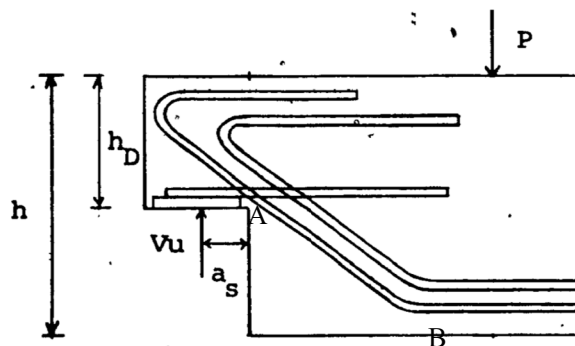

Figure 5. Design method proposed by Liem, (1983)

5- Design of the section at B using the principles of reinforced concrete.

The theoretical results revealed that the ultimate strength of dapped end with reinforcement of (45°) inclination is two times the strength of these with horizontal or vertical reinforcement.

In 1991, Barton et al. examined the efficiency of the STM model to simulate the dapped ends with different reinforcement configurations. Four details of dapped beam using the loading scheme shown in Figure 1c have been proposed. Two specimens were based on strut-and-tie models. Whereas, the other two specimens were designed according to the PCI Hand book method (1985) and the Menan/Furlong design procedure;Figure 6.

It was concluded that the strut-and-tie model might satisfy the detailing of the dapped beam fairly and that all of the methods mentioned above overestimate the capacity of the dapped ends but with different values. However, the STM procedure required a little more hanger reinforcement if compared with the other design procedures. Regarding their behavior, each of the specimens exhibited a ductile failure mode in which the steel yielded before the concrete failed.

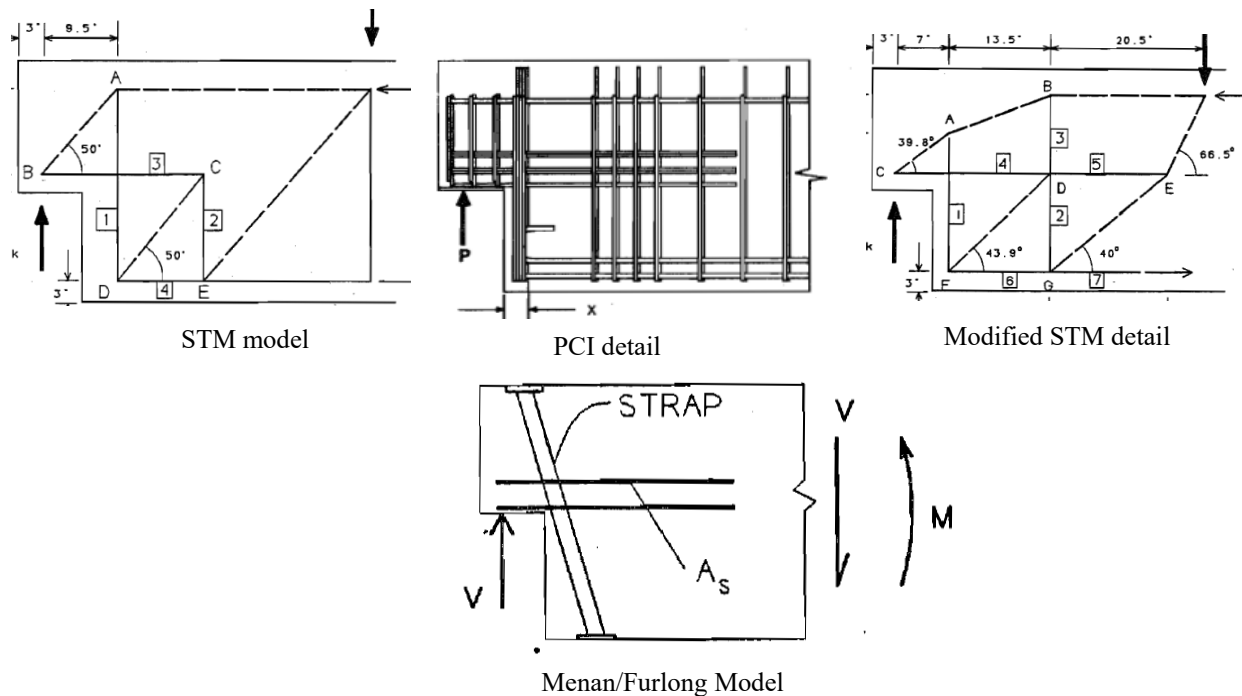

Figure 6. Details of dapped end reinforcement for specimens tested by Barton (1991)

In (2003), Lu et al. extended the knowledge of RC dapped end beams through testing 12 specimens. Several variables that believed to influence the behavior of dapped end beams were studied, as the concrete strength, (a/d) value, and the main horizontal steel of the dap. Nevertheless, (a/d) values still less than 1 and ranged between (0.56-0.89). Some specimens are made from normal weight concrete (34 MPa); others high strength concrete (69MPa) (which is the first time to consider high concrete). The loading setup shown in figure 1c was adopted. They proposed a new approach to estimate the shear strength of the dapped ends based on a system of strut and tie elements shown in Figure 7 as follows:

The relationship between vertical and horizontal shears (V_{dv} and V_{dh}) was expressed as:

$$\frac{V_{dv}}{V_{dh}} \approx \frac{jd}{a} \tag{16}$$

$$V_{dh} = C = T - Nc \tag{17}$$

$$V_{dv} = -D \sin\theta + F_h \tan\theta \tag{18}$$

$$\theta = \tan^{-1} \left(\frac{jd}{a} \right) \tag{19}$$

$$jd = d - kd/3. \tag{20}$$

$$Fh = A_{th}E_s\epsilon_h \leq F_{yh} \tag{21}$$

a' and D ; are the shear span and compression force in the diagonal strut respectively

F_h , F_{yh} and A_{th} are the tension force, yielding force and the cross sec. area of the horizontal tie respectively.

$$-D \sin \theta : F_h \tan \theta = R_d : R_h \tag{22}$$

R_d and R_h are the vertical shear ratios carried by the diagonal and horizontal mechanisms, which are calculated as:

$$\left. \begin{aligned} R_d &= 1 - \gamma_h \\ R_h &= \gamma_h \end{aligned} \right\} \tag{23}$$

$$\text{Where; } \gamma_h = \frac{2 \tan \theta - 1}{3}; \quad 0 < \gamma_h < 1 \tag{24}$$

They found that when $\theta \geq \tan^{-1}(2)$; all the shear is resisted by the horizontal mechanism; whereas for $\theta \leq \tan^{-1}(1/2)$; the shear is resisted by the diagonal mechanism. The test results revealed increasing concrete strength, amount of the horizontal lap reinforcement improved the shear capacity of dapped-end beams noticeably. In addition, An improvement of shear capacity was noticed when reducing (a/d) ratio. Also, the shear strengths predicted by the proposed model and the PCI method were compared with the test results. The comparison yielded that the PCI Design method yielded less accurate (underestimates) results and less values of shear capacity if compared with the proposed procedure.

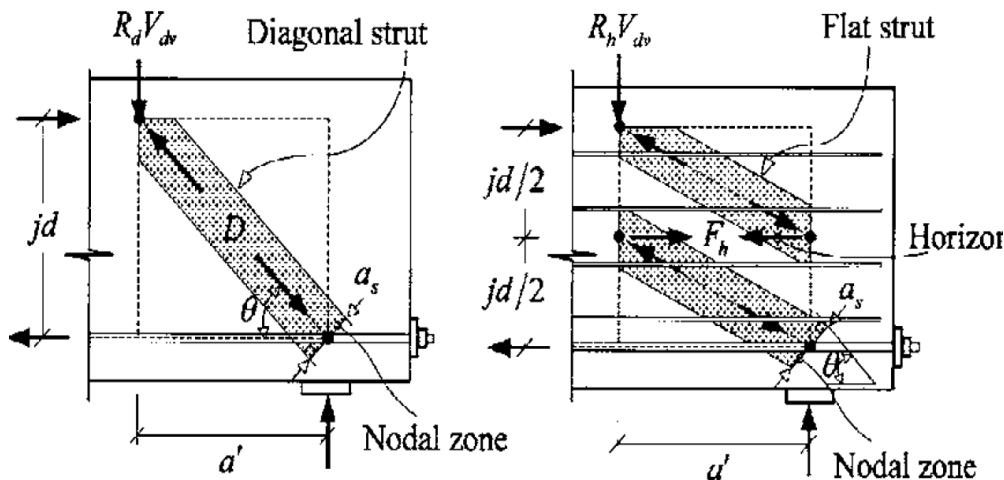

Figure 7. Strut and tie model proposed by Lu et al. (2003)

In 2005 Wang et al., tested 24 DEB up to failure. A value of (a/d) less than 1.0 was adopted with compressive strength of concrete between (11.32-18.12) MPa. Several configuration of inclined hanger reinforcement have been investigated. The main variables studied in this work were the depth of nib end, the type and distance to use the stirrups and the bent detail of the main steel.

They introduced a semi-empirical (Truss mechanism); Figure 8, for shear strength estimation as follows:

$$V_N = V_c + V_s + V_b \tag{25}$$

In which V_c , V_s , V_b are the contribution of concrete, vertical stirrups and bent bars, thus;

$$V_N = \beta_1 * f_c * b * h_{10} + \beta_2 * A_{sv} * f_{yv} + A_{sb} * f_y * \sin \alpha \tag{26}$$

$\beta_1, \beta_2, \beta_3$ are obtained from statistical regression analysis as 0.0546, 0.8583 and 1.00 respectively

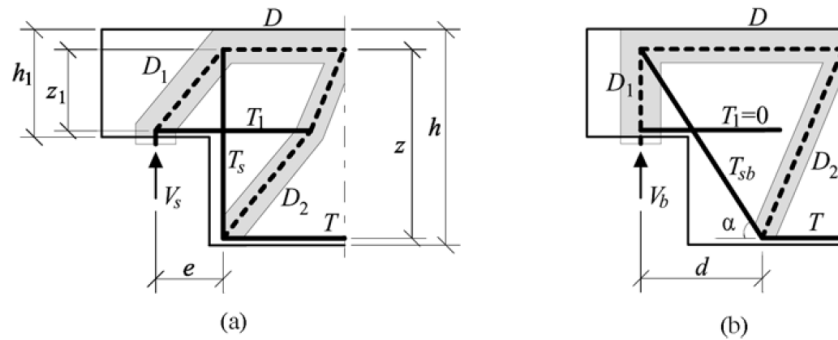

Figure 8. Internal forces in the analogous trusses proposed by Wang et al. (2005)

Regarding the longitudinal steel; if vertical stirrups are provided,

$$T_1 = 1.18 \frac{e}{h_{10}} * V_u \tag{27}$$

If the shear resistance of a dapped end beam is controlled by the flexural strength of its extended end, the shear strength can be calculated as:

$$V_N = \frac{A_{s1} * f_y * h_{10}}{1.18e} \tag{28}$$

From test, they observed the first cracks occurred at the reentrant corner of the dent with angle (40⁰-60⁰) from the horizontal.. A failure occurred when the tip of the diagonal crack that progressed gradually reduced the uncracked compression block noticeably. Then, a so called "shear-compression failure" occurred. In addition, it was found the dimensions of the cross-section of beam and dap (especially depth) have a significant effect on formation of the diagonal cracks and shear capacity. Furthermore, it was reported that there no significant effect of the web reinforcement on crack control. Whereas, the influence of stirrups inclination and longitudinal bent reinforcements were noticeable on the shear strength if compared with the closed vertical stirrups. Thus, it was suggested that nib depth not to be less than 0.45h (where h: full depth beam) and the effective range of the hanger stirrups to be half to full depth of dap end with a minimum cover of 40 mm.

The first use of steel fibers in dapped end beams was in 2008 by Mohamed and Elliott. 1% by volume hooked-end steel fibers was used to substitute partly the hanger reinforcing bars. The test setup shown in Figure 1c was adopted to study several variable; the reinforcement configuration, concrete strength as well as nib depth. The study included experimental tests of 20- self-compacting steel fiber RC dapped end beams.

A new softened strut-and-tie model was proposed; Figure 9; by which the diagonal shear compression failure, V_{DC} can be predicted as:

$$V_{DC} = (0.81K \zeta f_{cu} a_s b_s \sin \theta) + (1.66.\eta\theta. \eta1. \tau\phi. \lambda\phi. \zeta_f) b_w d, \tag{29}$$

$$K=1, f_{ck}=0.81f_{cu}$$

$$\xi = \frac{3.35}{\sqrt{f_{c'}}} \leq 0.52 \quad (\text{Lin et al.}) \tag{30}$$

ηθ, η1, λf: factors related with fibers, V_f: fiber content

τ_f: the fiber matrix bond taken from flexural strength tests of FRC prisms as 4.15 N/mm², (Swamy and Mangat, 1976)

f_{cu} cube strength, and θ is the failure plane angle,

Astr = is the area of diagonal strut, a_s and b_s: are the depth and width of the diagonal strut respectively

They found that comparing the results of the proposed method, the PCI, traditional shear summation and Wang et al. methods with the experimental tests emphasized that the strut-and-tie concept of the proposed model was the best approach to design the disturbed zone of the dapped ends. The shear force is transferred entirely through the compressive diagonal strut. In addition, the mode of failure of the tested beams is of shear-compression type along the diagonal strut and the strength of steel reinforcement is less effective. The substitution of 1% by volume of

steel fibers was obtained to have good influence in both type of beams, in either full addition or partial substitution over secondary reinforcement.

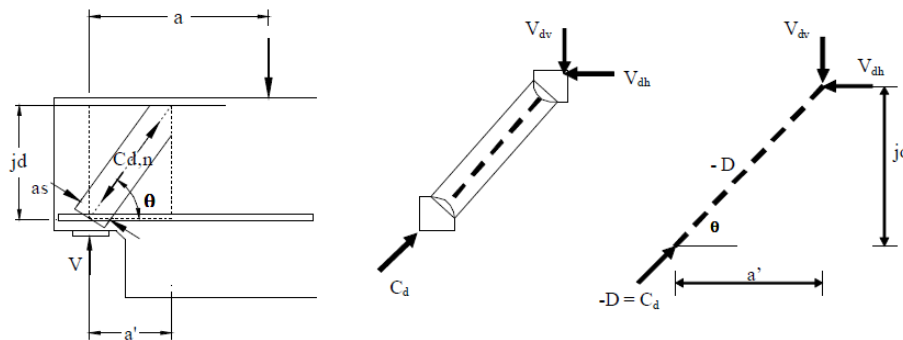

Figure 9. Strut and tie model proposed by Mohamed and Elliott (2008)

In 2009, Peng investigated two DEB with four different reinforcing details as shown in figure 10. The compressive strength of concrete was 33MPa and (a/d) value of 1.0. The specimens were tested under the loading setup depicted in Figure 1a. The STM model adopted by CSA 2004 Standard was used in analysis of one specimen while the others were designed according to PCI method. The variables considered were the anchorage of the hanger reinforcement and the nib main reinforcement.

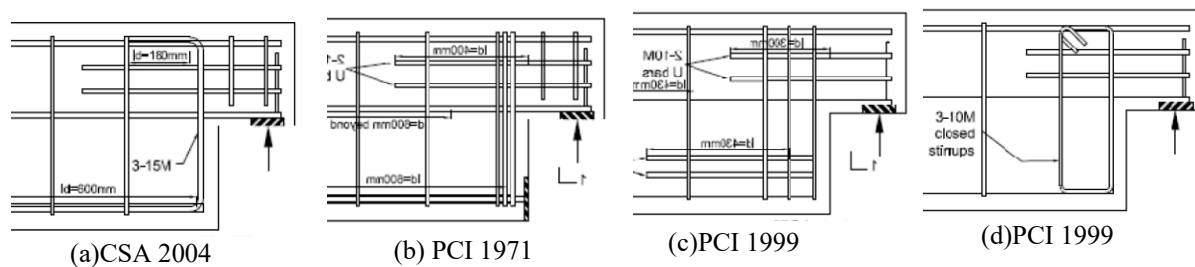

Figure 10. Details of dapped end tested by Peng (2009)

Results revealed that the STM models was a conservative approach and that the early versions of 1971 and 1999 PCI method gave poor design and detailing requirements thus result in brittle failure modes. In addition, the proper anchorage reinforcement details have a considerable effect on ductility, type of failure and shear capacity of about 44%. In addition, they demonstrated that placing hanger reinforcement close to the dapped end enhanced the shear capacity of the dapped ends.

A new mechanism analysis have been proposed by Yang et al. (2011), depending on the energy principle, Figure 11, to estimate the failure plane and the associated shear strength of RC dapped-end beams. Results of 47 dapped-end beams tested experimentally by Lu et al. (2003), Mattock & Chan (1979), Taher(2005) and Wang et al. (2005) have been adopted to calibrate the proposed approach against different techniques (PCI, STM model based on ACI318-05).

It was reported that the both PCI design method and the simplified strut-and-tie model overestimate shear strength in contrast adequate prediction by the proposed mechanism analysis was found. Furthermore, they demonstrated that the influence of shear span-to-overall depth ratio of beam and horizontal tensile loads on the shear capacity of dapped-end beams might not be described adequately by the PCI design method. This is besides the hanger, longitudinal, and shear reinforcement in the dapped end. Moreover, the effects of such variables estimated by the mechanism analysis was similar to the results whose the STM model yielded.

In 2013, Ahmad, et al. studied the effect of the depth of the extended end on the response of the RC dapped end beams. Four specimens have been tested under the loading scheme shown in Figure 1a. The concrete compressive strength of 35.45 MPa with (a/d) value less than 1.0. Specimens were divided into two groups having total depth/nib depth of 18"/11"and 12"/7" respectively.

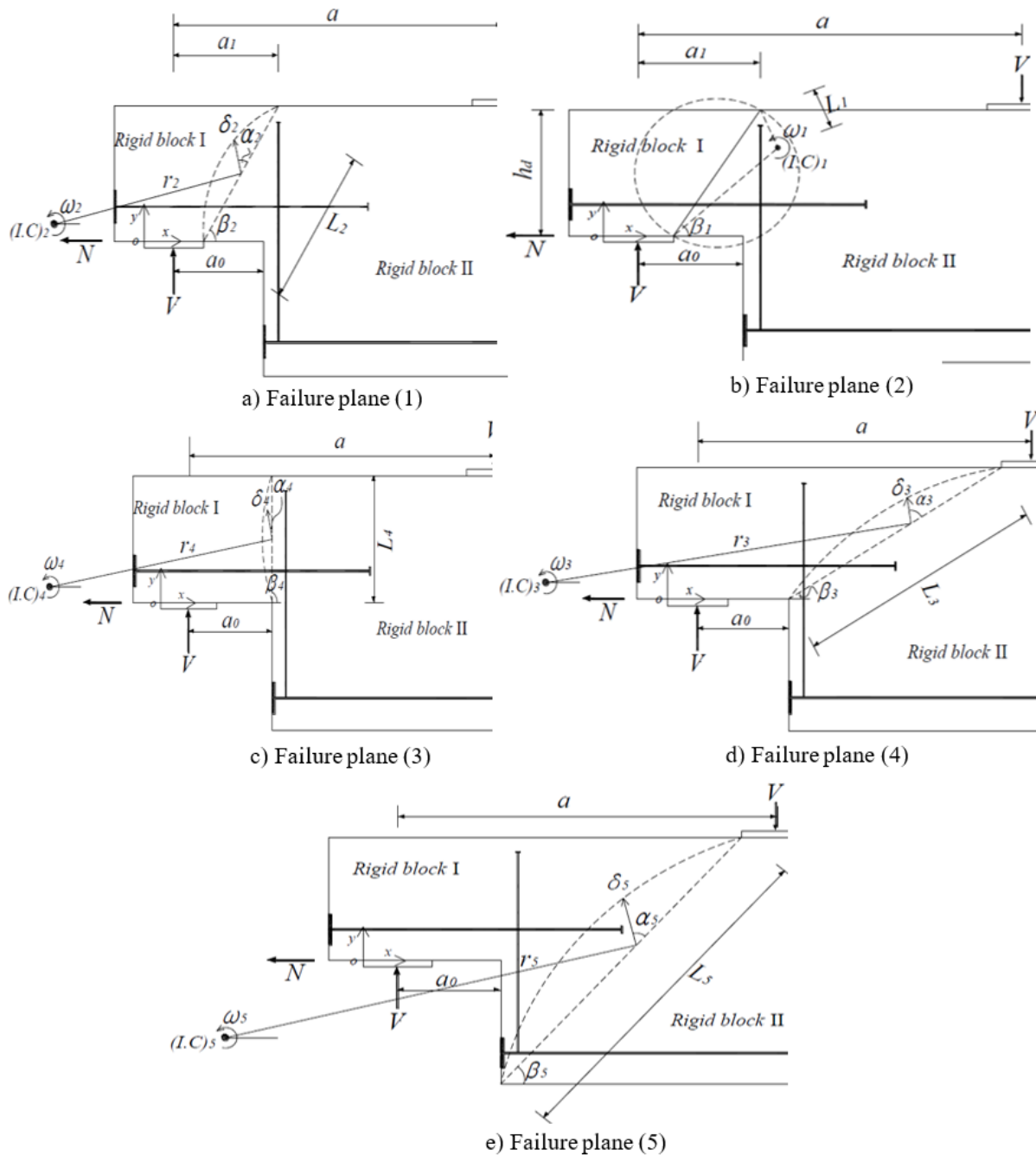

Figure 11. Potential failure mechanism dapped end beams proposed by Yang et al. (2011)

It was concluded that the shear capacity was effected by (shear span /depth) ratio rather than the overall depth of the beam. On the other hand, the STM model produced an underestimate solution for high dap depths only, and design for DEB using STM modelled to results influenced by the strut inclination. In addition, the reinforced concrete dapped end beams have the ability to resist loads beyond formation of the diagonal crack due to arch action.

In 2014, Aswin, et al. check the validity of the STM modelling based on (ACI- 318-08, Euro Code 2 and BS 8110) codes and PCI method. They used results of (Wang et al., 2005) to estimate the failure loads. In addition, Some variables were discussed such as concrete compressive strength, nib dimensions, (a/d) ratio, types and distance of hanger stirrups, bent configuration of the longitudinal reinforcements, main nib end and hanger steel reinforcement. He concluded that Euro Code 2 and BS 8110 were less accurate in comparison with PCI method and ACI-318-08.

Furthermore, it was reported that beams with inclined stirrups, bent reinforcement less than (90^0) , higher dapped height, closer stirrups distance and higher number of stirrups provided higher failure loads.

In 2015, Aswin, et al., tested four large-scale RC-DEB specimens adopting loading setup shown in Figure 1d. Three were made of normal strength concrete (NSC) of $f_c=27\text{MPa}$, while the fourth was high strength concrete with PVA fibers ($f_c=79\text{MPa}$) at dapped end only. The shear span-depth ratio (a/d) was 0.91 to satisfy the PCI requirements. They studied three variables, which are amount of dapped end reinforcement, main longitudinal steel, and grade of concrete at the dapped-end zone. It has been found that the use of high strength concrete in the dapped area may increase the failure load by (51.9%) and Increasing the amount of nib and main flexural reinforcements gave an enhanced in the failure load by (62.2%) and (46.7%) respectively.

In 2015, Lu, et al., introduced a modified model to estimate the diagonal compression strength of dapped-ends based on strut and tie model and according to Lin et al. (Lin et al., 2003). 24-DEB with shear span-to-depth ratio (a/d) ranged between (1.19-1.51) with loading setup shown in Figure 1c. The compressive strength of concrete was taken in the range (32.5-62.9) MPa. Several parameters were studied as compressive strength of concrete, (a/d) ratio, and longitudinal nib and hanger stirrups of the dapped-end beams. Regarding the mode of failure, all of the specimens failed by flexure mode and that the shear capacity might be enhanced with higher concrete compressive strengths and with smaller values of a/d ratio.

The proposed model can be expressed as follows:

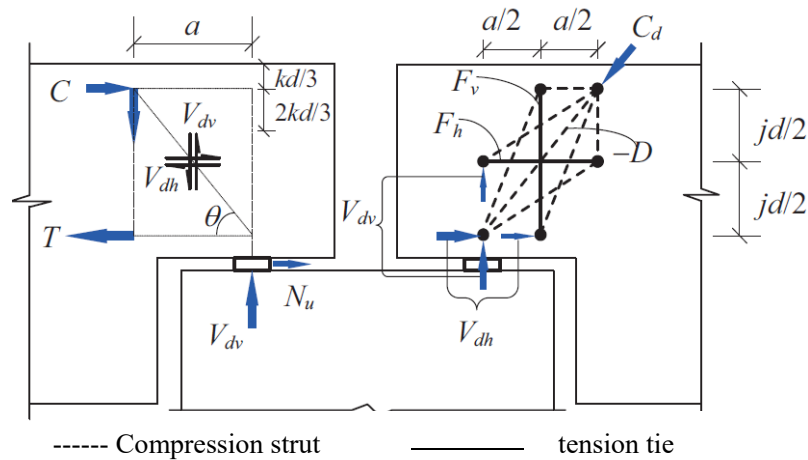

Figure 12. The model proposed by Lu et al. (2015)

$$C_d = (K_h + K_v - 1) * f'_c * A_{str} \tag{31}$$

The horizontal and vertical tie indices can be estimated as follows (Lu et al., 2003; Lu et al., 2012):

$$K_h = 1 + (\bar{K}_h - 1) \frac{A_{vh} f_{yh}}{F_h} \leq \bar{K}_h; \tag{32}$$

$$\bar{K}_h \approx \frac{1}{1 - 0.2(\gamma_h + \gamma_h^2)}; \tag{33}$$

γ_h as in equation (24)

$$\bar{F}_h = \gamma_h (\bar{K}_h \xi f'_c A_{str}) \cos \theta \tag{34}$$

$$K_v = 1 + (\bar{K}_v - 1) \frac{A_{vh} f_{yh}}{\bar{F}_v} \leq \bar{K}_v \tag{35}$$

$$\bar{K}_v \approx \frac{1}{1 - 0.2(\gamma_v + \gamma_v^2)} \tag{36}$$

$$\gamma_v = \frac{2 \cot \theta - 1}{3}; \tag{37}$$

$$\bar{F}_v = \gamma_v (\bar{K}_v \xi f'_c A_{str}) \sin \theta \tag{38}$$

θ and ξ as in equations (19) and (30)

$$A_{str} = t_s * b_s \quad (39)$$

$$t_s = \sqrt{kd^2 + a_b^2} \quad (40)$$

The shear strength of dapped-ends due to diagonal compression failure can be calculated as:

$$Vd_{v\,calc} = Cd \sin \theta \quad (41)$$

A total of 24-specimens that were tested in this study besides 44 others tested experimentally by Mattock and Chan (1979), Lu et al. (2003) and Lu et al. (2012) have been used to verify the proposed model. The proposed model can consistently predict the shear strength of dapped ends at diagonal compression failure with different shear span-to-depth ratios, compressive strength of concrete and parameters of flexural tensile reinforcement. Predictions that are more conservative have been obtained from the STM of the ACI Code.

In 2016, Desnerck, et al., tested experimentally, four DEB with the loading setup shown in Figure 1a. The compressive strength of concrete was 52 MPa and (a/d) value of about 1.0 was adopted. Several reinforcement details of dapped ends were investigated. The control specimen was designed by STM model. Whereas the other beams were with either missing diagonal reinforcement, missing nib reinforcement or a reduced hanger reinforcement as shown in Figure 13.

It was found that that the STM underestimates the shear strength of the dapped ends and the control specimen has failed at the re-entrant corner. furthermore, removing the diagonal reinforcement or U-bar nib reinforcement, results in a nib failure whereas the reduction of shear(hanger) reinforcement produced a shear failure in the full-depth section of the beams with a reduction of the failure load was smaller which about (10%). The greatest effect on the failure load has been recorded in beams without diagonal reinforcement bars with a reduction of about (39%) compared with the control specimen. This investigation yielded also, that in all specimens, cracks initiated at the re-entrant corner with a load level corresponding to 20-33% of the failure load and angle around (40-45) $^\circ$ except the beam without a U-bar where the angle was higher (75) $^\circ$.

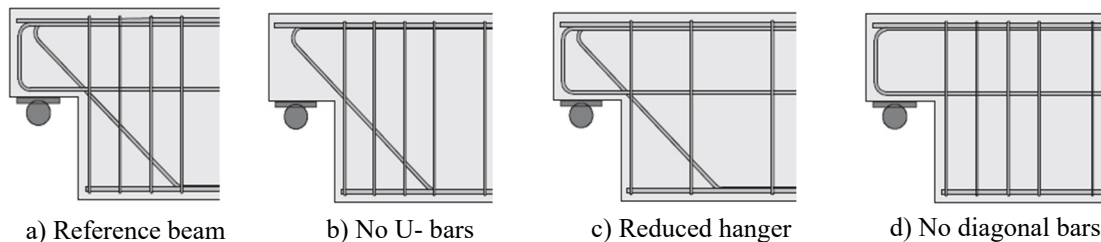

Figure 13. Reinforcement layouts for specimens tested by Desnerck et al. (2016)

Later, in (2018), the same authors tested Experimentally 12 half-joint beams to study several variables that may affect performance of such members. Such parameters are as compressive strength, reinforcement layout, Influence of detailing Influence of deterioration, The STM models were adopted to analyze all specimens.

Results revealed that in all cases, that the STM method underestimates the shear capacity, as would be expected from a lower bound method. However, the underestimation varied significantly within a range of 16-57%. Moreover, for all the specimens, the predicted load carrying capacity from the STM was governed by the yielding of the reinforcing bars (under-reinforced half-joint) or insufficient anchorage lengths, rather than exceeding the capacity of the concrete struts. This was the case even for the lower concrete strength specimens.

Shakir et al. (2018) tested experimentally 14-specimens to study the performance of reinforced self-compacting concrete dapped end beams strengthened with CFRP sheets. Two values of (a/d) namely (1.5 and 1.0) were adopted. Two specimens have been considered as reference beams. While, four beams were made with some reduction in horizontal nib or hanger reinforcement. Eight specimens have been upgraded with several arrangements by CFRP sheets. It found that (a/d) ratio has a noticeable effect on behavior of dapped end beam. For the specimens with full-reinforcement, the reduction of (a/d) ratio from (1.5) to (1.0), led to increase the failure load capacity by about (17%) and transferring the failure mode from diagonal tension in the extended end to the diagonal tension in the reentrant corner. The reduction of hanger reinforcements by about (50%), results in reduction of ultimate load about (13%) regardless of values (a/d) ratio. However, the reduction of nib reinforcement by about (60%), result in reducing the ultimate load by about (56%) for a/d=1.5 and (15%) for a/d=1.0.

3. Conclusions

1. The first cracks initiated from the reentrant corner of the dent and spreads towards the compression zone of the beam with an angle (400-600) from the horizontal. While, the angle of inclination of the failure crack in all beams was approximately 30°. Thus, any strengthening method should take in consideration the inclination of the strengthening material with respect to the crack.
2. In most beam specimens, cracking initiated with a load value ranging between 20-33% of the ultimate load, Thus it is expected that the strengthening in early stages of loading will be more advantageous than the final stages.
3. Regarding the economical view, it was reported that inclined reinforcement with (45o) are ($\sqrt{2}$) times more than the horizontal reinforcement in terms of the amount of steel required and that the shape of dapped end has no effect on the ultimate shear strength. Therefore, it is recommended to use small size of for the main steel of the beam and bending some of the bars within the dapped end up with (30o- 45o) from the horizontal.
4. The shear capacity is effected by (shear span /depth) ratio rather than the overall depth of the beam. Considerable enhancement was recoded with smaller values of a/d ratio.
5. Several approaches and methods have been investigated to design the dapped ends as the PCI 1971 then, PCI 1999 method; traditional shear summation; strut-and-tie concept; Euro Code 2 and BS 8110 methods. Others have been introduced, such as mechanism analysis Wang et al. method.
6. It was reported by most of researchers that the strut-and-tie concept is the most suitable approach to design the disturbed region of the dapped ends. Due to its ability to satisfy the detailing of the dapped beam fairly. While, the PCI Design method yielded less accurate results of shear capacity. Euro Code 2 and BS 8110 were less accurate in comparison with PCI method and ACI-318-08(STM models).
7. The PCI design procedure does not efficiently characterize the effect of shear span-to-overall depth ratio of beam, horizontal tensile loads, hanger reinforcement, longitudinal nib reinforcement, and shear reinforcement in the dapped end on the shear strength of the nib ends. The effects of such variables estimated by the mechanism analysis of (Yang et Al., 2011) was similar to those that the strut and tie model yields. Both the proposed mechanism analysis and STM model obviously indicate that the critical failure path of dapped-end beams may be affected by such parameters.
8. The reinforced concrete dapped end beams have the ability to resist loads beyond formation of the diagonal crack due to arch action.
9. It was observed that introducing some inclination in the bottom of a dapped end yield more adequate than the rectangular one. This is due to the small stress intensity compared with the rectangular nib end.
10. Regarding the behavior of the dapped ends, some specimens exhibited some ductile behavior up to failure in which the steel yielding occurred before the concrete failed in compression. The longitudinal reinforcement of nib yielded at the range of (70-95) % of the maximum load. Others, shear-compression type along the diagonal strut with compression spalling and the top face of the beam became inflated close to the point of load application. Some studies addressed four failure modes were observed which are diagonal tension cracks within the full-depth of the web, diagonal tension cracks within the nib. Flexure-shear cracking in the full-depth precipitated by longitudinal splitting of the web and strand bond failure, crushing of the diagonal strut near the bottom corner of the stem. The patterns of modes of failures of all the specimens were governed by the diagonal tension at the reentrant corners.
11. Different variables were studied as shear span "a", the amount of hanger, configuration and detailing of hanger reinforcement, the anchorage of the hanger reinforcement, the concrete strength, (a/dnib) value, dnib / hbeam. In addition, the main horizontal nib reinforcement, effective distance to provide the stirrups, bent form of the longitudinal reinforcements, the effect of horizontal reaction, type of web reinforcement in dapped regions, length of horizontal extension of hanger reinforcement and strand profile.
12. The effective range of the hanger stirrups was proposed half to full depth of dap end. Placing the first hanger reinforcement close to the dapped end (minimum cover of 40 mm) with closer stirrups distance and higher number of stirrups enhanced the shear capacity. Also, Increasing shear reinforcement of the web increases strength and ductility after cracking. The strut-and-tie design procedure required slightly more shear reinforcement compared to the other design procedures as PCI and the Menan/Furlong design procedures.
13. The dimensions of cross-section of beam and dap (especially depth) have a significant effect on formation of the diagonal cracks and shear capacity. Thus, it was suggested that (nib depth/ depth of beam) not to be less than 0.45.

14. Increasing the concrete strength of the disturbed region improved the shear strength of dapped-end beams noticeably but not in direct proportion to the square root of the concrete strength. it was found the using high strength concrete(79MPa) rather than (28MPa) in the dapped area improved the failure load by (51.9%).
15. The closed vertical stirrups is less effective in shear strength than those with inclined orientation are and bent configuration. Using inclined hanger or bars steel bars result in better serviceability performance expressed by cracking control, i.e. minimizing crack width and crack development rate. An Improvement in the capacity of the dapped end beams by about 30% was recorded in comparison with the vertical hanger detail.
16. The proper anchorage reinforcement details have a considerable effect on ductility, type of failure and shear capacity of about 44%. The horizontal extension of the hanger reinforcement in the bottom of the web should not be less than 1.7ld. Adopting the 180o bends at the nib can be considered as good anchorage methods of the bars. and that the early versions of 1971 and 1999 PCI method gave poor design and detailing requirements thus result in brittle failure modes.
17. Increasing amount of the horizontal dap reinforcement improved the shear strength of dapped-end beams noticeably. Increasing the amount of nib and main flexural reinforcements gave an enhanced in the failure load by (62.2%) and (46.7%) respectively.
18. The substitution of 1% by volume of steel fibers was obtained to have good influence on the dapped end beams, in either full addition or partial substitution over secondary reinforcement.
19. When removing the diagonal reinforcement or U-bar nib reinforcement, a nib failure occurred whereas reducing the hanger reinforcement produced a shear, failure in the full-depth section of the beams with a reduction of the failure load was smaller which about (10%). The greatest effect on the failure load has been seen in the beams without diagonal reinforcement bars with a reduction of about (39%) compared with the control specimen.
20. Different schemes were used in practice to strengthen the dapped end region, (L-, CZ, C-, Z-, inclined L-shapes and welded Wire Reinforcement (WWR)) with ultimate capacities of 35% to 74%. More than the factored design load. However, the inclined L configuration yielded good performance in comparison to other forms because the hanger reinforcement is nearly parallel to the diagonal tension field.
21. There no significant effect of the web reinforcement on the rate of crack propagation and the strength of steel reinforcement is less effective.
22. For all the specimens, the predicted load carrying capacity from the STM was governed by the yielding of the reinforcing bars (under-reinforced sections) or inadequate anchorage lengths, rather than exceeding the capacity of the concrete struts. This was the case even for the low concrete strength specimens.
23. Several other methods can be investigated rather than those previously suggested to enhance the performance of beams with dapped ends as adopting composite -section dapped ends, making the hanger reinforcement as coiled spiral or using reactive powder concrete within the dapped ends only. This may be very effective for precast construction subjected to severe loading, or effects of seismic forces.

References

- Ahmad, S., Elahi, A., Hafeez, J., Fawad, M., & Ahsan Z. (2013). Evaluation of the Shear Strength of Dapped Ended Beam. *Life Science Journal*, 10(3).
- Aswin, M., Mohammed, B., Liew, M. S., & Syed, Z. I. (2015). Root cause of reinforced concrete dapped-end beams failure. *International Journal of Applied Engineering Research*, 10(22), 42927-42933.
- Aswin, M., Syed, Z. I., Wee, T., & Liew, M. S. (2014). Prediction of Failure Loads of RC Dapped-End Beams. *Applied Mechanics and Materials*, 567, 463-468. <https://doi.org/10.4028/www.scientific.net/AMM.567.463>
- Barton, et al. (1985). PCI Design Handbook (Third Edition), Prestressed Concrete Institute, Chicago, Illinois, 6.28-6.32.
- Barton, D. L., Anderson, R. B., Bouadi, A., Jirsa, J. O., & Breen, J. E. (1991). *An Investigation of Strut-And-Tie Models for Dapped Beam Details*. Research Report Number 1127-1.
- Desnerck, P., Lee, J. M., & Morley, C. T. (2016). Impact of the reinforcement layout on the load capacity of reinforced concrete half-joints. *Engineering Structures*, 127, 227-239. <https://doi.org/10.1016/j.engstruct.2016.08.061>
- Desnerck, P., Lee, J. M., & Morley, C. T. (2018). Strut-and-tie models for deteriorated reinforced concrete half joints. *Engineering Structures*, 161(1), 41-54. <https://doi.org/10.1016/j.engstruct.2018.01.013>

- Liem, S. K. (1983). *Maximum shear strength of dapped-end or corbel*. M.Sc. Thesis, Concordia University, Montreal, Quebec, Canada.
- Lin, I. J., et al. (2003). Shear Strength of Reinforced Concrete Dapped-End Beams. *Structural Engineering and Mechanics*, 16(3), 275-294., cited by Mohamed R N, Elliott (2008). <https://doi.org/10.12989/sem.2003.16.3.275>
- Lu, W. Y., Lin, I. J., Hwang, S. J., & Lin, Y. H. (2003). Shear strength of high-strength concrete dapped-end Beams. *Journal of the Chinese Institute of Engineers*, 26(5), 671-680. <https://doi.org/10.1080/02533839.2003.9670820>
- Lu, W. Y., Chen, T. C., & Lin, I. J. (2015). Shear Strength of Reinforced Concrete Dapped-End Beams with Shear Span-To-Depth Ratios Larger Than Unity. *Journal of Marine Science and Technology*, 23(4), 431-442. <https://doi.org/10.6119/JMST-015-0511-1>
- Mattock A. H., & Chan T. C. (1979). *Design and Behavior of Dapped-End Beams*. PCI Journal/November-December. <https://doi.org/10.15554/pcij.11011979.28.45>
- Mattock, A. H. (1976). Design Proposals for Reinforced Concrete Corbels. *PCI Journal*, 21(3), May-June, 18-42. <https://doi.org/10.15554/pcij.05011976.18.42>
- Mohamed, R. N., & Elliott, K. S. (2008). *Shear Strength of Short Recess Precast Dapped End Beams Made of Steel Fibre Self-Compacting Concrete*. 33rd Conference on Our World in Concrete & Structures: 25-27, August, Singapore.
- Peng, T. (2009). *Influence of Detailing On Response of Dapped End Beams*. M.Sc. Thesis, McGill University, Montréal, Canada.
- Schäfer, K. (1996). *Strut-and-Tie Models for the Design of Structural Concrete: Notes of Workshop*. Department of Civil Engineering, National Cheng Kung University, Tainan, Taiwan, 140p.
- Shakir, Q. M., Abd, B. B., & Jasim, A. T. (2018). Experimental and Numerical Investigation of Self -Compacting Reinforced Concrete Dapped End Beams Strengthened with CFRP Sheets. *Journal of University of Babylon for Engineering Sciences*, 26(7). <https://doi.org/10.29196/jubes.v26i7.1482>
- Swamy, R. N., & Mangat, P. S. (1976). The Interfacial Bond Stress in Steel Fiber Cement Composites. *Cement and Concrete Research*, 6(5), 641-650. [https://doi.org/10.1016/0008-8846\(76\)90028-4](https://doi.org/10.1016/0008-8846(76)90028-4)
- Taher, S. F. (2005). *Strengthening of critically designed girders with dapped ends*. Structures & Buildings, January. <https://doi.org/10.1680/stbu.2005.158.2.141>
- Wang, Q., Guo, Z., & Hoogenboom, P. C. J. (2005). Experimental investigation on the shear capacity of RC dapped end beams and design recommendations. *Structural Engineering and Mechanics*, 21(2), 221-235. <https://doi.org/10.12989/sem.2005.21.2.221>
- Yang, K. H., Ashour, A. F., & Lee, J. K. (2011). *Shear Strength of Reinforced Concrete Dapped-End Beams using Mechanism Analysis*. The University of Bradford Institutional Repository. <https://doi.org/10.1680/mac9.00006>

Copyrights

Copyright for this article is retained by the author(s), with first publication rights granted to the journal.

This is an open-access article distributed under the terms and conditions of the Creative Commons Attribution license (<http://creativecommons.org/licenses/by/4.0/>).